

REVISIONS				
REV	ZONE	DESCRIPTION	DATE	APPROVED

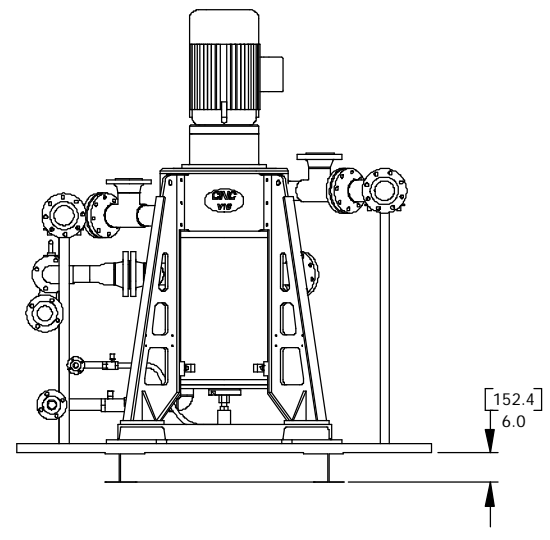

UNLESS OTHERWISE SPECIFIED DIMENSIONS ARE IN INCHES		CONTRACT NO.		PARTS LIST	
TOLERANCES		DRAWN	DATE	CINC CARSON CITY, NV 89706	
DECIMALS	ANGLES	DESIGN		CENTRIFUGAL SEPARATOR SKID LAYOUT - 2 UNITS	
.XX ± .01	1/4	QUALITY		V16	
.XXX ± .010		MANUFACTURING		SIZE	REVISION
BROKEN EDGES AND MAX FILLET RADIUS MAX		CHECKED BY		D	V16X2
1:50 MACHINE SURFACES				SCALE	RELEASE DATE
TEMPER PER ANSI Y14.5M (1982) DO NOT SCALE DRAWING				1:12	
CITY	NEXT ASSEMBLY	MATERIAL			SHEET 1 OF 1
NA					N/C

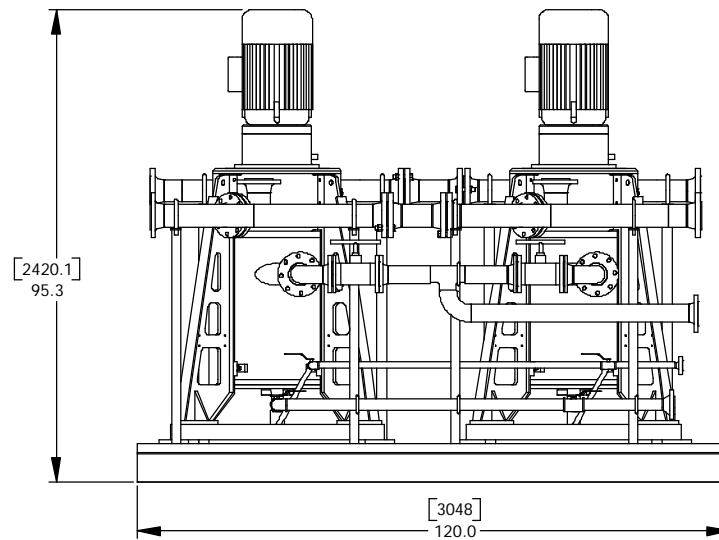
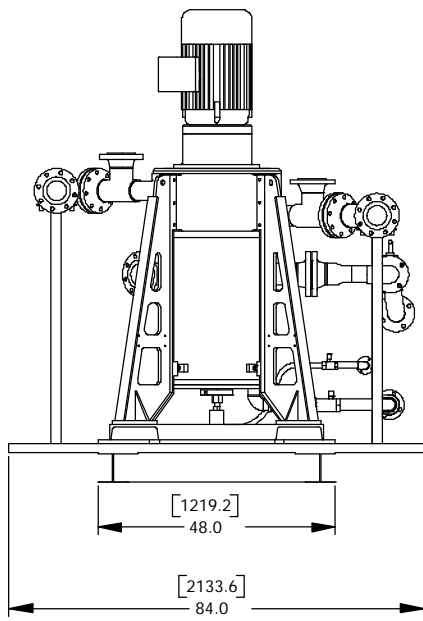
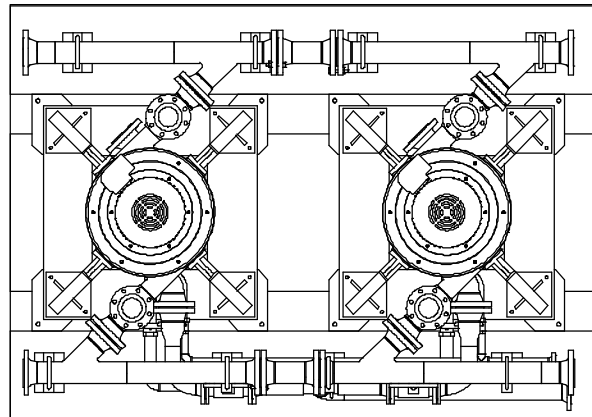